



## SM330M (FB)

60-CELL LINE



Peimar monocrystalline solar panels, produced using a combination of innovative production processes and advanced engineering techniques, provide customers with maximum output and super high performance.

This allows fewer panels to be used to generate more energy, ideal if space is restricted or environmental conditions are challenging. Modern design, using matching black cells and frames and a very long lifespan ensure this monocrystalline are a great option.

**30** YEAR LINEAR POWER WARRANTY  
**30** YEAR PRODUCT WARRANTY



**PERC TECHNOLOGY**



**PID FREE**



**MODULE FIRE PERFORMANCE: CLASS 1**



**ANTI-REFLECTIVE GLASS**



**QBE INSURANCE**  
*Product Liability Insurance QBE*

### Cells



60 CELLS  
MONO 5BB / 9BB M3 | PERC

158.75 x 158.75 mm / 6.25 x 6.25"

### Frame



COMPACT AND STURDY | 40 mm

ANCHORABLE ALSO ON THE SHORT SIDE <sup>(5)</sup>

## Electrical Characteristics (STC) <sup>(1)</sup>

## SM330M (FB)

Nominal Output (Pmax) <sup>(2)</sup>	330 W
Sorting Tolerance	0/+5 W
Voltage at Pmax (Vmp)	34.35 V
Current at Pmax (Imp)	9.61 A
Open Circuit Voltage (Voc) <sup>(2)</sup>	41.91 V
Short Circuit Current (Isc) <sup>(2)</sup>	10.18 A
Maximum System Voltage	1500 V
Maximum Series Fuse Rating	15 A
Module Efficiency	19.78%
Protection class against electric shock	Class II

## Mechanical Characteristics

Solar Cells	60 (6 x 10) M3 monocrystalline PERC
Solar Cells Size	158.75 x 158.75 mm / 6.25 x 6.25"
Front Cover	3.2 mm / 0.13" thick, low iron tempered glass
Back Cover	TPT (Tedlar-PET-Tedlar)
Encapsulant	EVA (Ethylene vinyl acetate)
Frame	Anodized aluminium alloy, double wall
Frame finishing	Black
Backsheet finishing	Black
Diodes	3 Bypass diodes serviceable
Junction Box	IP67 rated
Connector	MC4 or compatible connector
Cables Length	900 mm / 35.43"
Cables Section	4.0 mm <sup>2</sup> / 0.006 in <sup>2</sup>
Dimensions	1665 x 1002 x 40 mm / 65.5 x 39.4 x 1.57"
Weight	18.6 Kg / 41 lbs
Max Load (Test Load) - SF	5400 Pa - 15' <sup>(3)</sup>

## Temperature Characteristics

NMOT <sup>(3)</sup>	45±2 °C
Temperature Coefficient of Pmax	-0.37 %/°C
Temperature Coefficient of Voc	-0.28 %/°C
Temperature Coefficient of Isc	0.042 %/°C
Operating Temperature	-40 °C - +85°C

## Packaging <sup>(4)</sup>

Pallet dimensions	1720 x 1200 x 1210 mm / 67.72 x 47.24 x 47.64"
Pieces per pallet	27
Weight	535 Kg / 1179 lbs

## Certifications

Fire Resistance Rating	Class of reaction to fire 1 (UNI g177)
Fire Performance Rating	Type 1 (UL 61730)
PID free	IEC TS 62804-1:2015
Salt mist	IEC 61701:2011
Ammonia	IEC 62716:2013
Product Certificate	IEC 61215-1, IEC 61215-1-1, IEC 61215-2, IEC 61730-1, IEC 61730-2, UL 61730

## Dimensions

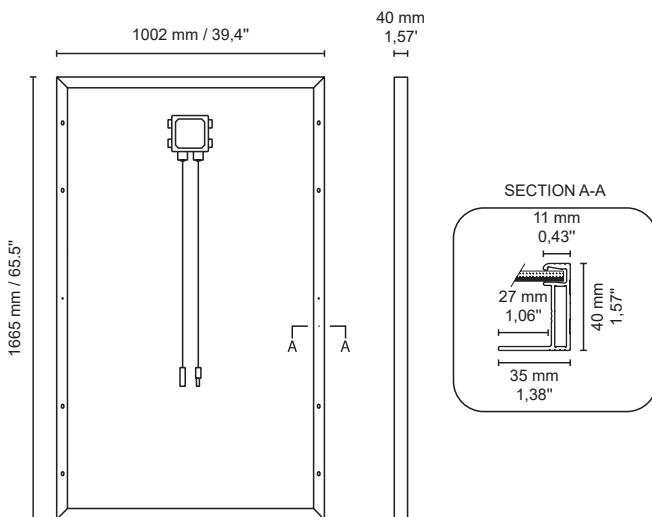

## Current/Voltage Characteristics

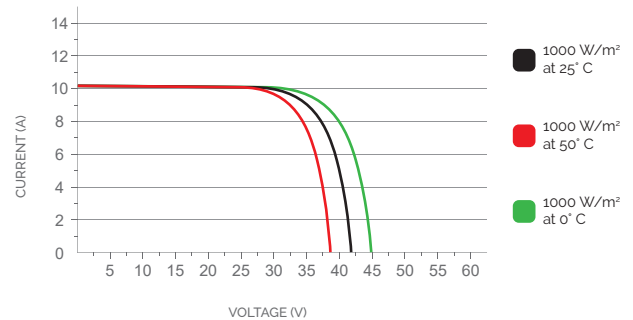
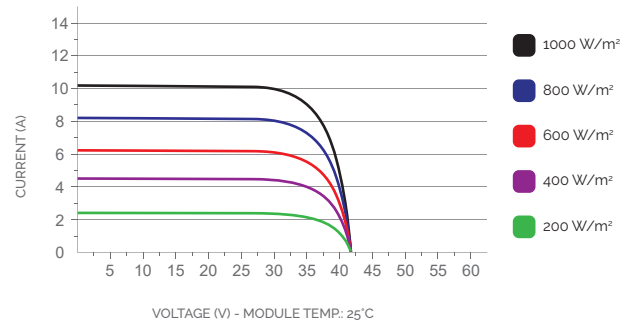

1. STC: (Standard Test Condition) Irradiance 1000W/m<sup>2</sup>, Module Temperature 25°C, Air Mass 1.5

2. Pmax, Voc, Isc measurement tolerance: ±3%

3. NMOT: Nominal Module Operating Temperature. Irradiance 800W/m<sup>2</sup>, Air 20°C, Wind speed 1m/s

4. Pallets can be stacked up to two

5. Consult the installation manual for the relative mounting configurations